



# SEWGS applications and process integration



European conference on CCS Research, Development and Demonstration  
10 – 11 February 2009, Grand Hotel Oslo





Simulation tool

SEWGS system integrated in NGCC

- Calibration of code on the experimental results achieved;
- Preliminary system optimization for NGCC: three different levels of integration investigated;

Conclusions

Future work and acknowledgements

Contribution to Common benchmark task force

SEWGS integration in IGCC



**GS** is an in-house Fortran code originally developed to estimate the performances of **Gas/Steam** power cycles and later extended to handle essentially all the processes encountered in advanced power plants.

The main features of **GS** are:

- Modular structure;
- Turbomachine efficiencies are evaluated by built-in correlations accounting for the machine operating conditions and the machine size;
- Built-in correlations to predict gas turbines cooling flows;
- Chemical equilibrium calculated by Gibbs free energy minimization;
- Thermodynamic properties of perfect gas mixtures calculated by means of NASA polynomials;
- Thermodynamic properties of water and steam conforming to IAPWS-IF97 equations.



# Turbine cooling simulation



open loop cooling air

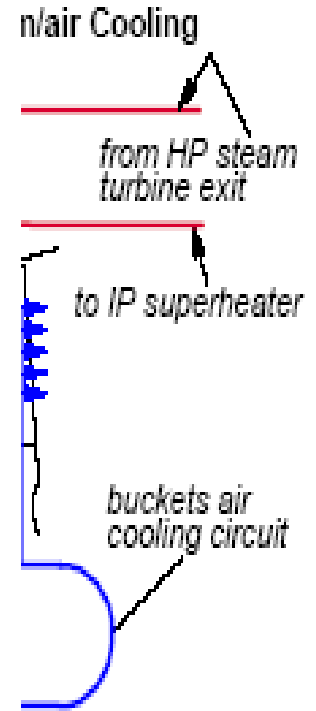
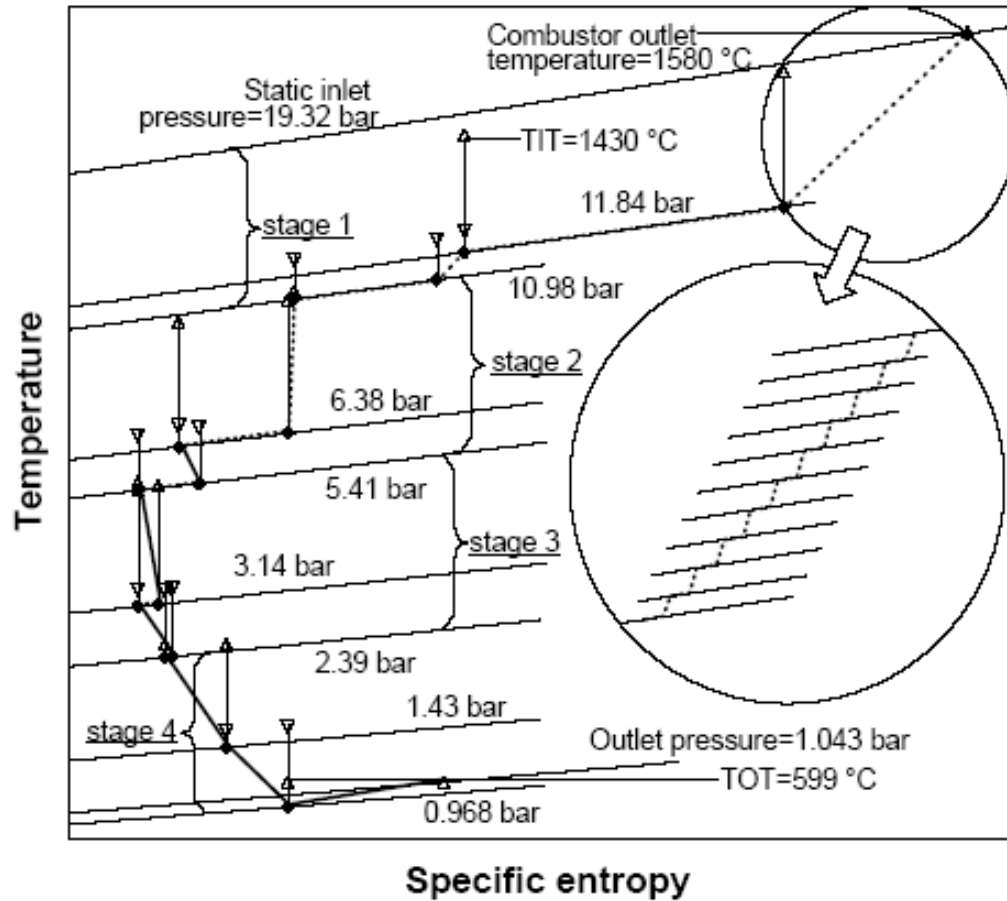
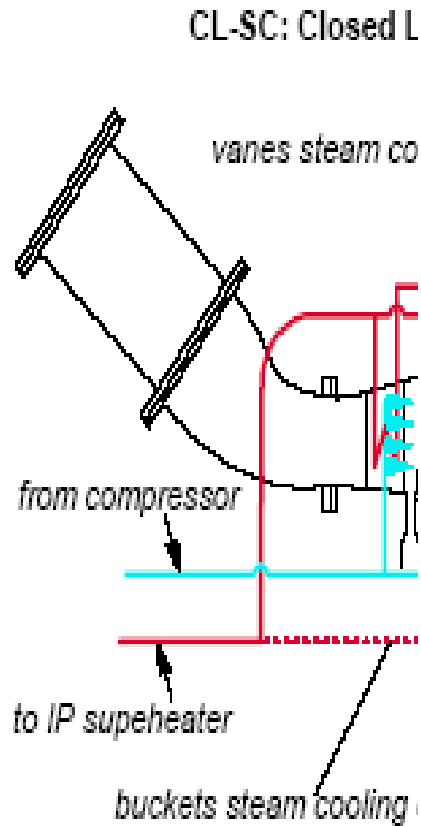

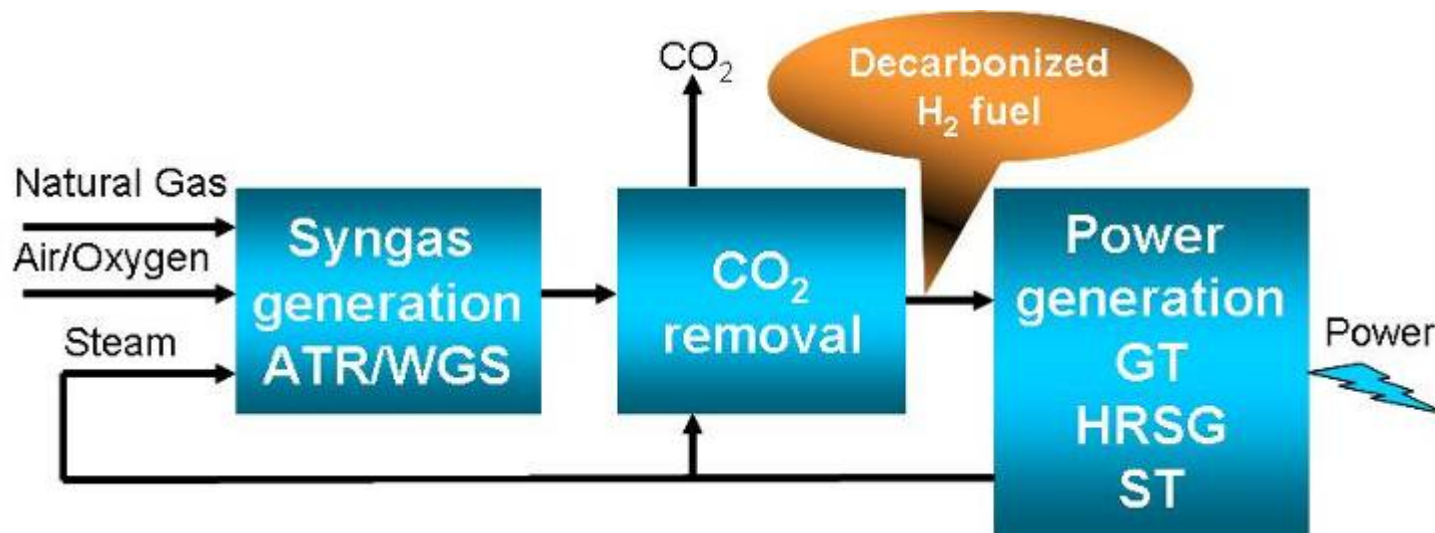

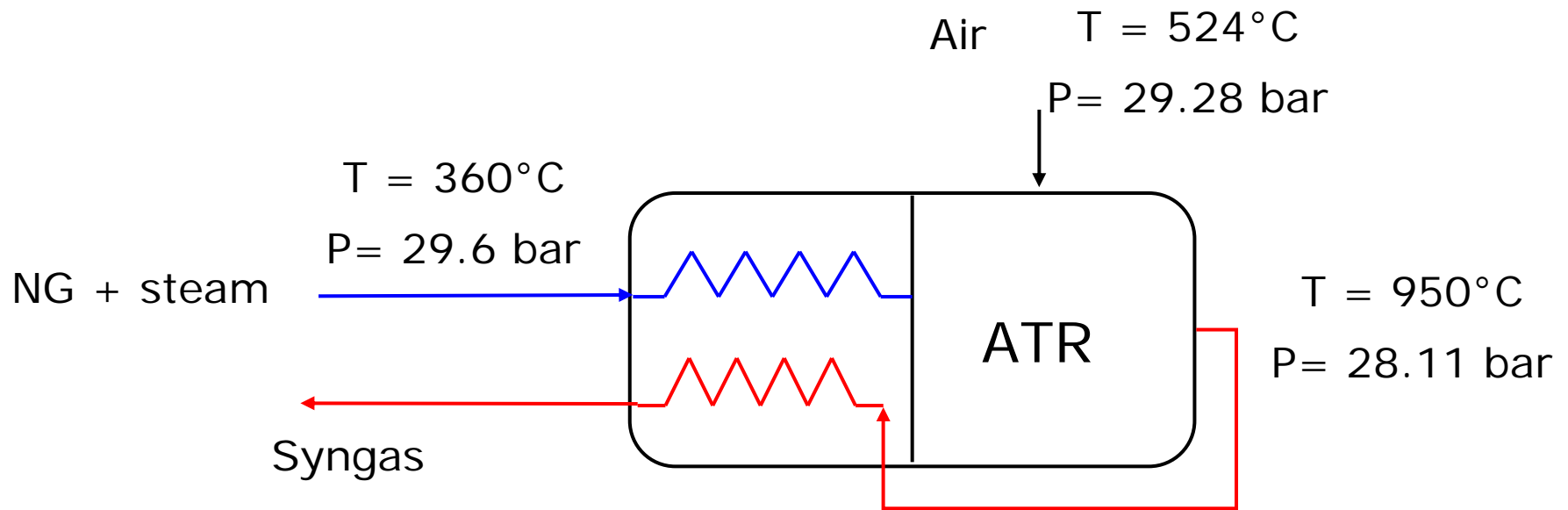

## GHR - ATR:

- Prereforming up to a temperature of  $650^{\circ}\text{C}$ ;
- Air-blown ATR;
- Pressure set in order to achieve a pressure ratio of 1.5 at combustor inlet (fuel pressure/air pressure);
- S/C ratio 1.1 (about 96% of  $\text{CH}_4$  conversion).



## Pressure Swing Adsorption process

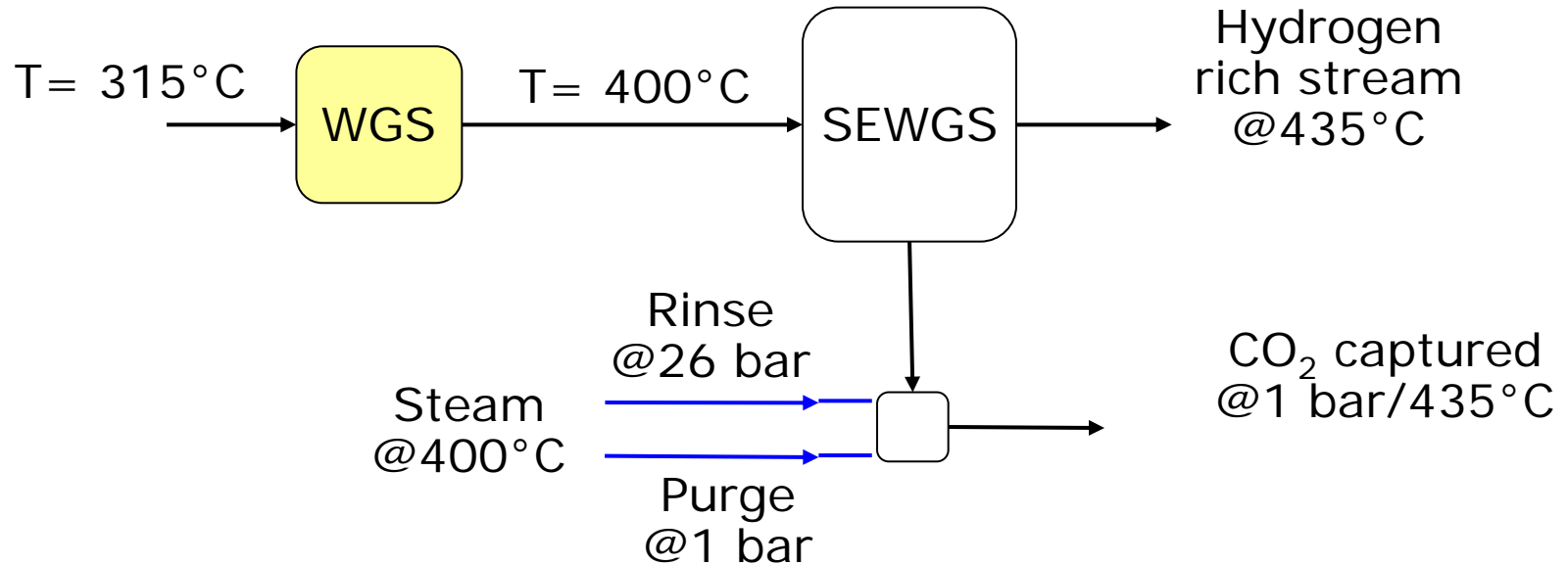

### SEWGS:

- CO conversion 99%;
- $\text{CO}_2$  captured in order to achieve a 96% of Carbon Capture Ratio;
- $\text{CO}_2$  purity 98% v.d.



## Gas Turbine:

- "F-Class"
- Pressure ratio        17
- TIT                      1335°C
- Efficiency              39.4%

## HRSG

- Three pressure level (130,30, 4 bar)
- Condensing pressures 0.04 bar

Power cycle simulations calibration on available constructor's data (TIT, TOT, pressure ratio, etc.)

# Plant Lay-out (level of integration 0)

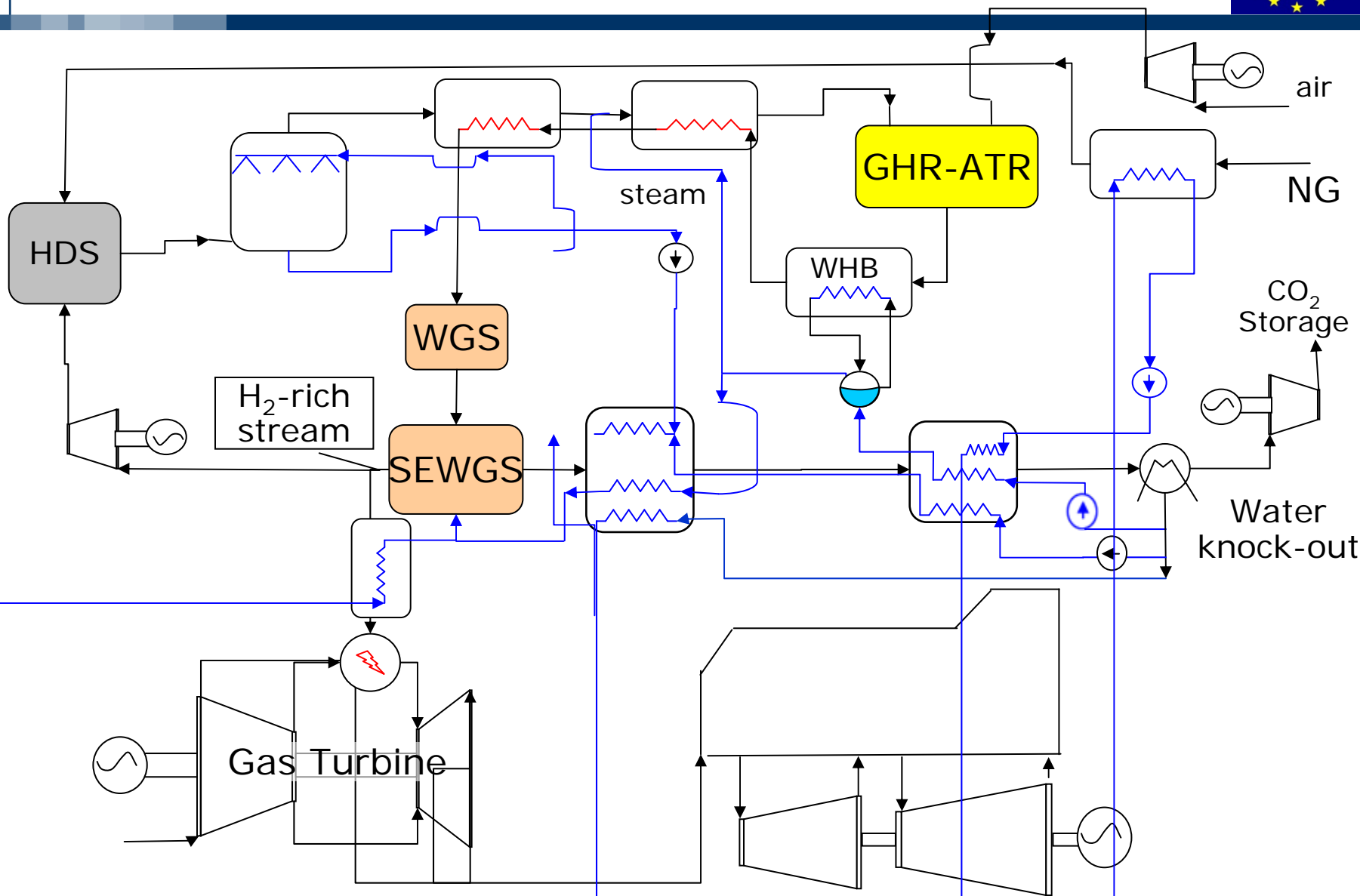

# Plant Lay-out (level of integration 2)

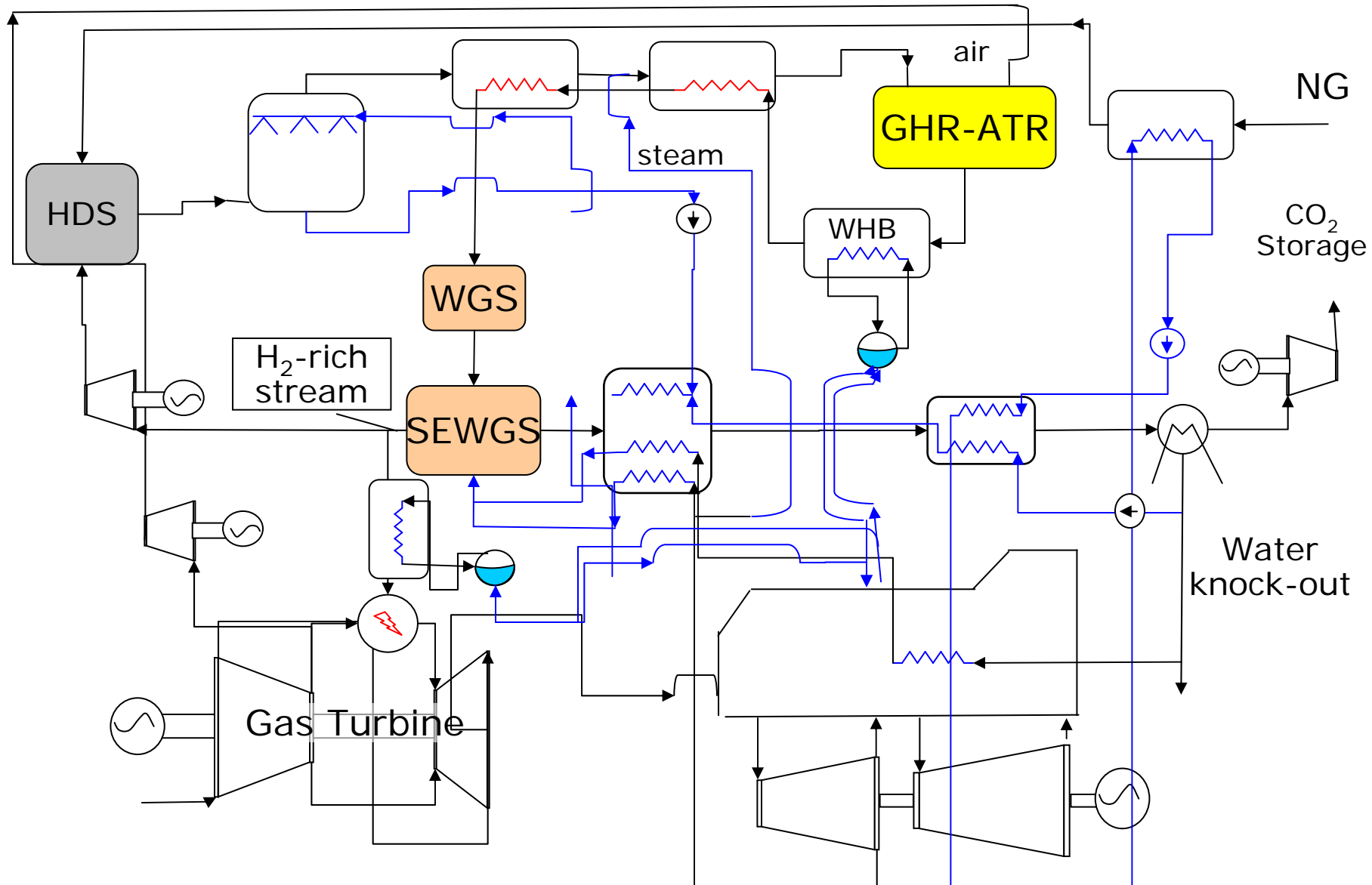



# Water balances (Integration 2)

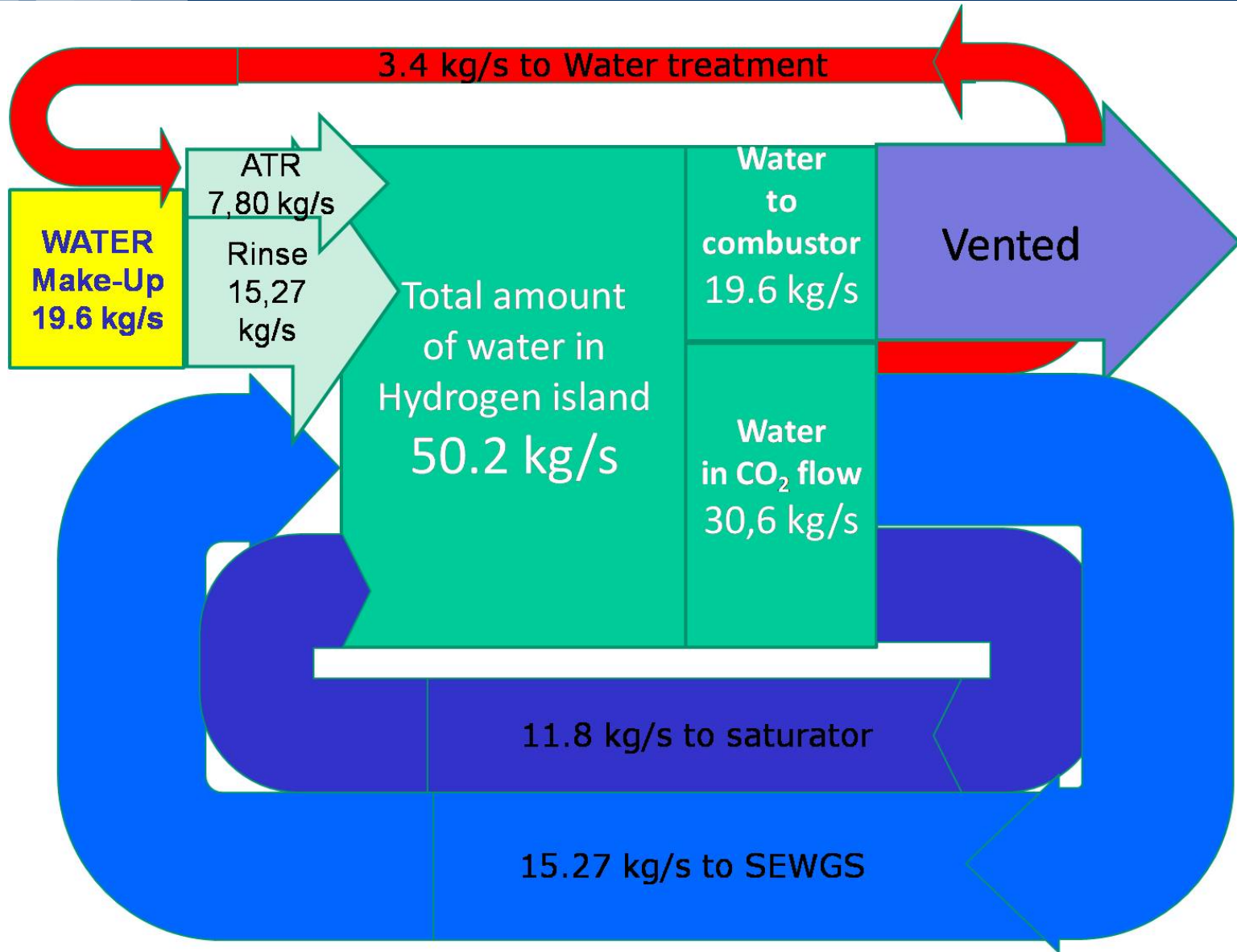



# Efficiency Vs Temperature

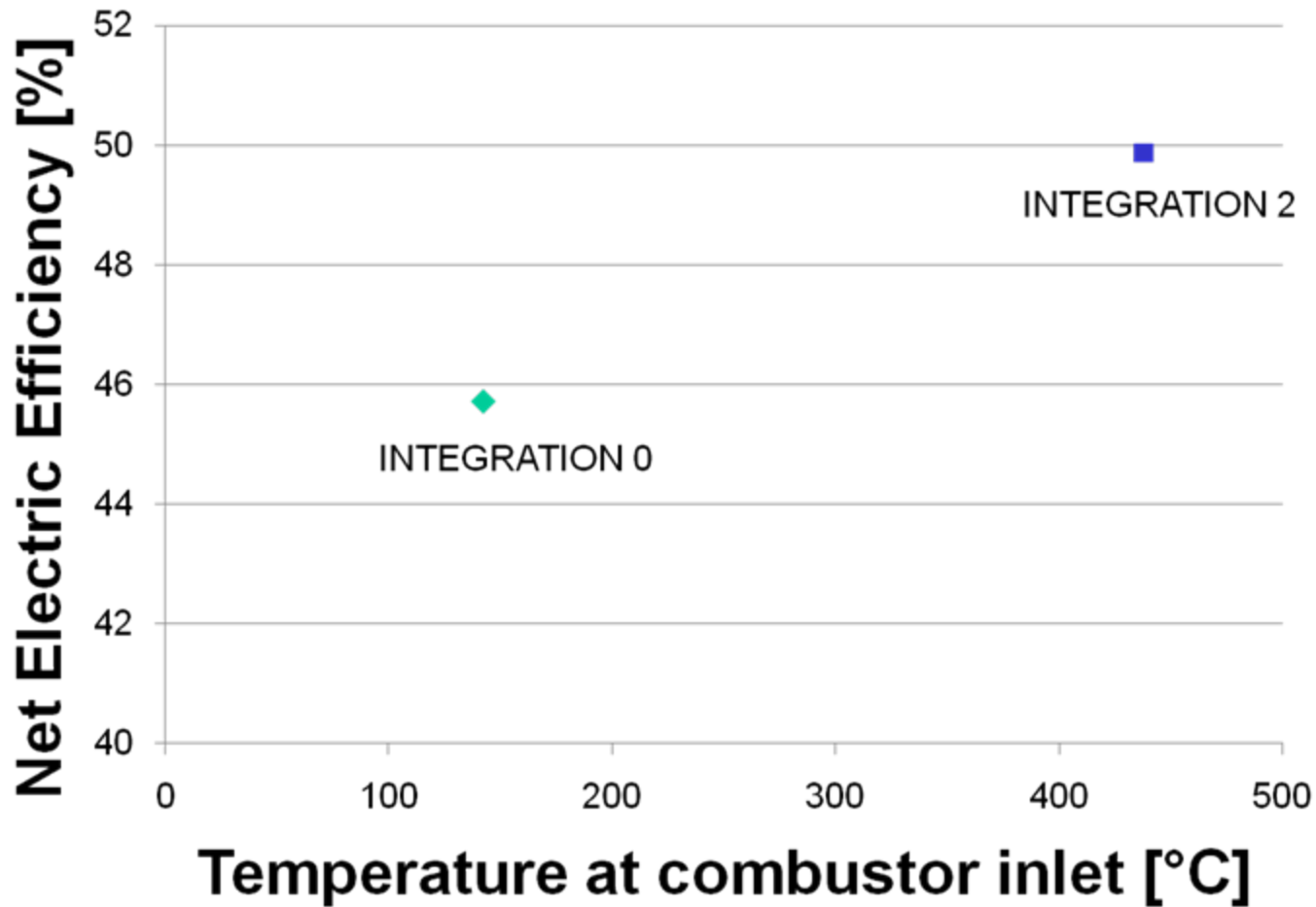



	NGCC w/o capture	NGCC with SEWGS (lev 0)	NGCC with SEWGS (lev 2)
Gas Turbine, MW	281.5	323.6	287.2
Steam Cycle Net Power, MW	140.8	136.9	126.2
CO <sub>2</sub> compressor, MW	N/A	-17.2	-15.4
Auxiliaries, MW	-3.8	-48.5	-10.6
Net power Output, MW	418.5	394.7	387.4
Thermal power input, MW	717.8	863.7	776.8
Net Electric Efficiency, %	58.3	45.7	49.9
Emissions (g <sub>CO2</sub> /kWh <sub>el</sub> )	346	18.9	19.6
CO <sub>2</sub> avoided, %	N/A	94.5	94.3



- Components performances are calibrated on available specifications of commercial systems;
- Three level of SEWGS integration in NGCC are considered: configuration from a “stand-alone” Hydrogen Island to a fully integrated version;
- Performances can vary from 46% up to 50% depending on integration level, with a carbon avoided of 94%;
- Efficiency is affected (about 2%) by fuel temperature at combustor inlet;
- Compared to conventional pre-combustion technology, SEWGS has similar net electric efficiency with higher CO<sub>2</sub> avoided;



- Sensitivity analysis of system performances at different working temperature of SEWGS and different ratio of rinse and purge steam;
- SEWGS integration in IGCC.



*The CAESAR project has received funding from the European Community's Seventh Framework Programme FP7/2007 -2013 under grant agreement n° 213206.*



 POLITECNICO DI MILANO

# Thank you for your attention!



[www.gecos.polimi.it](http://www.gecos.polimi.it)

[giampaolo.manzolini@polimi.it](mailto:giampaolo.manzolini@polimi.it)

